

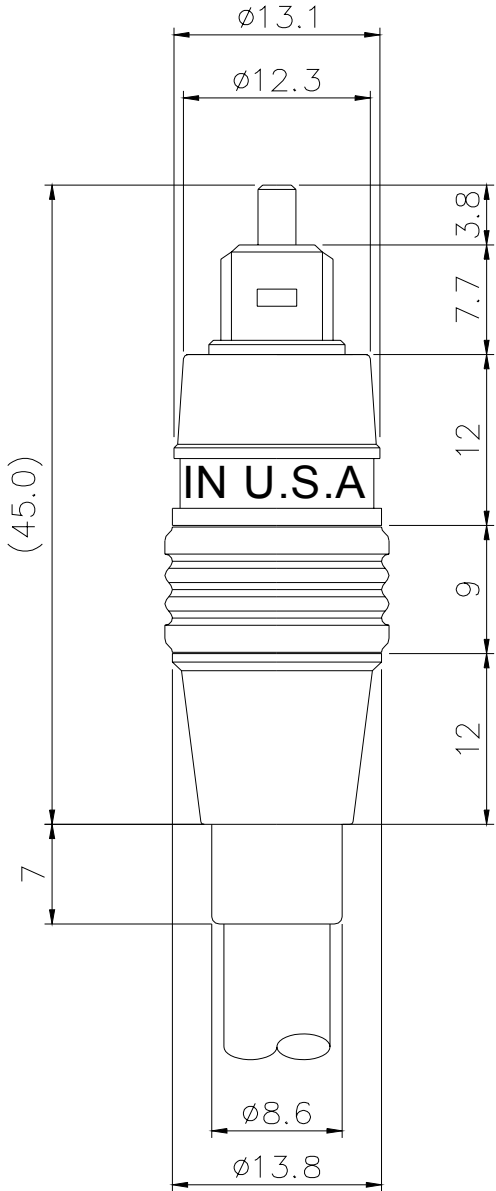

### 3. TOSLINK DIMENSION



名稱

DESCRIPTION.

OPTICAL FIBER CABLE

圖號

DRAWN NO.

SP-0944

SHEET

2

## 4. CABLE SPECIFICATION

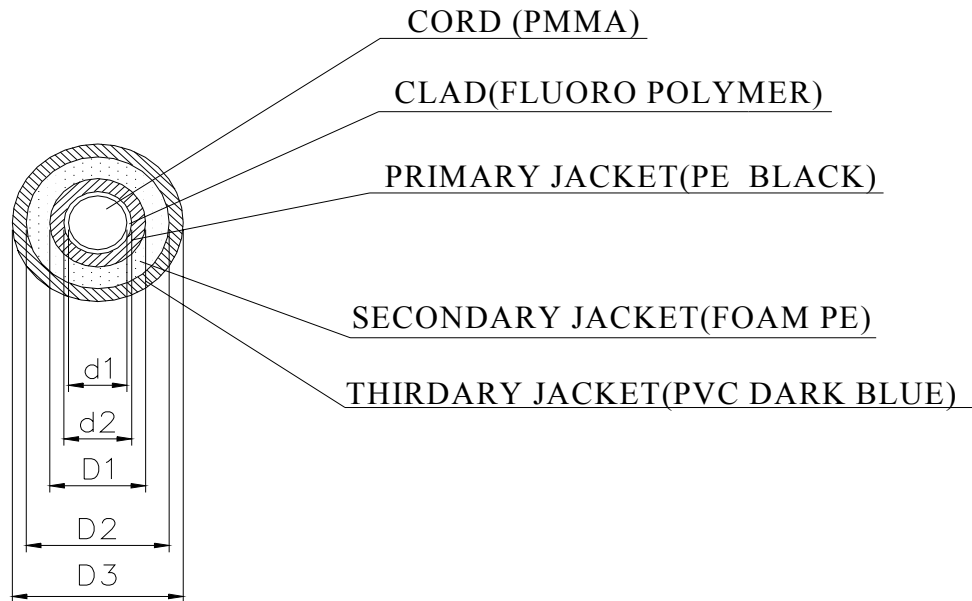

d1... CORE DIAMETER	± 0.98mm
d2... CLAD DIAMETER	± 1.0mm
D1... PRIMARY JACKET DIAMETER	± 2.2±0.07mm
D2... SECONDARY JACKET DIAMETER	± 5.0±0.1mm
D3... THIRRDARY JACKET DIAMETER	± 7.0±0.2mm

### 4-1. CABLE CHARACTERISTIC

ITEM	UNIT	SPECIFICATION
STORAGE TEMPERATURE	°C	-40 ~ +85°C
OPERATION TEMPERATURE	°C	-40 ~ +85°C
MINIMUM BENDING RADIUS	mm	30

# 5.CHARACTERISTIC

## 5-1 Mechanical / Optical Characteristic

ITEM	CONDITIONS	JUDGEMENT
Transmission loss	$\lambda_p=650\text{nm}$	See blow.
Terminal strength	Apply static load of 16N for 30 sec at optional direction to the tip of plug.	No defects such as crack and loose at tip. Shall satisfy the mechanical and optical characteristics.

## 5-2 Environment

ITEM	CONDITIONS	JUDGEMENT
Temperature cycle	-20°C(30min) 25°C(10min) 70°C(30min) 10 cycle .	Transmission loss variation 1dB or less.
Pulling strength	Plug side - cord 20N 30sec Plug side - tip 16N 30sec	
Optic connector operation	Use TORX170 500 times. (TOSLINK)	Insertion force 5.9N(0.6Kgf)~39.2(4.0Kgf) Withdrawal force 5.9N(0.6Kgf)~39.2(4.0Kgf)
ABS Non-Migration	Refer to Ambical temperature : 54±1°C Relative : Not specified Duration humidity : 24±1H Weight : 500±25g	When visually inspected. Any staining of the area of the abs that was in contact with the test pieces shall hardly be recognized.

## 5-3 Endurance Test

ITEM	CONDITIONS	JUDGEMENT
High temperature storage	70 °C , 240 hours	Fibre optic output variation $\leq$ 1dB
Low temperature storage	-30 °C , 240 hours	
Humidity resistance	40 °C , 90% , 240 hours	
Operation temperature	-40°C ~+85°C	

REMARK : Do testing after 2 hours in normal temperature.

NAME	Transmission loss
POF-AC70605AC-C	1.0 dB or less
POF-AC70609AC-C	1.5 dB or less
POF-AC70610AC-C	1.5 dB or less
POF-AC70615AC-C	1.5 dB or less
POF-AC70620AC-C	2.0 dB or less
POF-AC70630AC-C	3.0 dB or less

# 6. PACKAGE

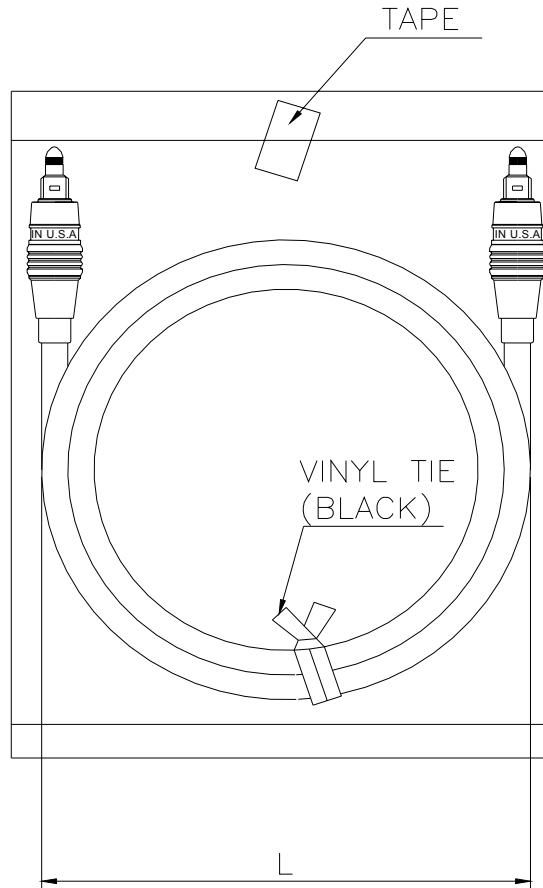

NAME	L
POF-AC70605AC-C	(90)
POF-AC70609AC-C	(110)
POF-AC70610AC-C	(120)
POF-AC70615AC-C	(120)
POF-AC70620AC-C	(120)
POF-AC70630AC-C	(120)